

MOBILE MOUNTING BRACKET MB-53

Thank you for purchasing the MB-53 MOBILE MOUNTING BRACKET. The MB-53 is designed for mounting the IC-A200 VHF AIR BAND TRANSCEIVER in a vehicle. A speaker, microphone and DC cable are supplied with the MB-53.

Please read these instructions thoroughly for the best results.

CONNECTIONS

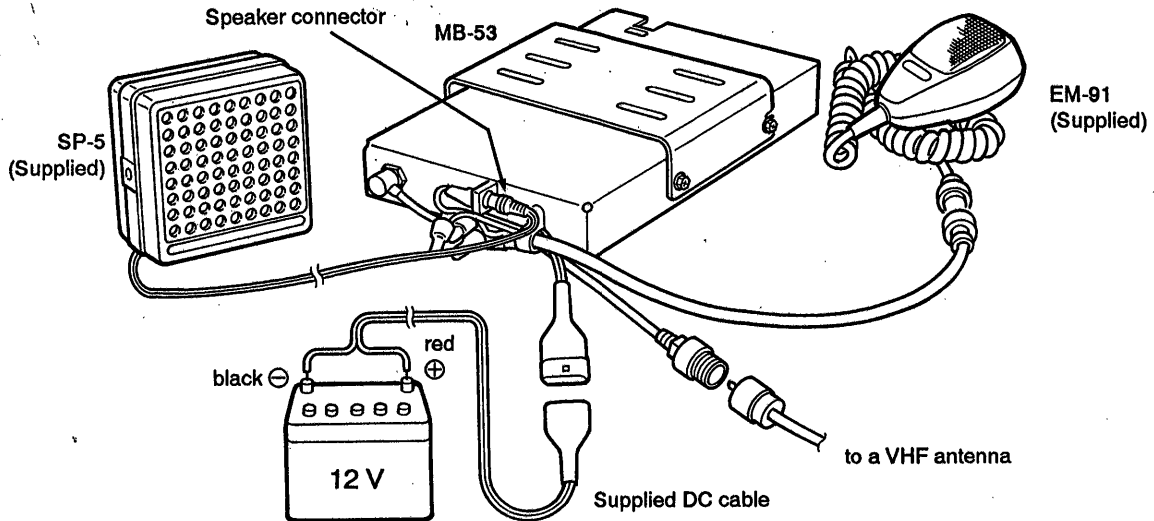

INSTALLATION

- ① Set the metal catch on the transceiver as shown at right, then install the transceiver into the mounting rack.

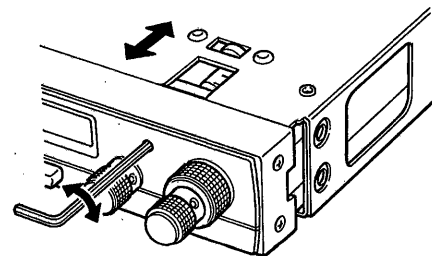
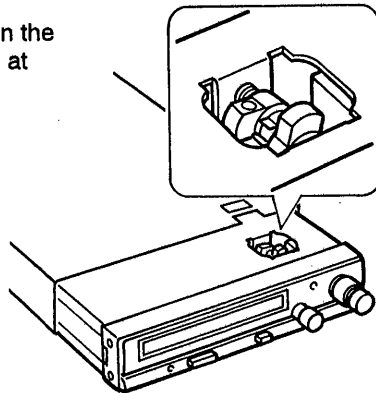

- ② Use a 3/32 inch wrench to attach the transceiver to the MB-53.
 - Clockwise rotation installs the transceiver into the bracket.
 - DO NOT overtighten the metal catch.

MOUNTING

When using tapping screws

When using nuts

Use 6 screws to mount the bracket.

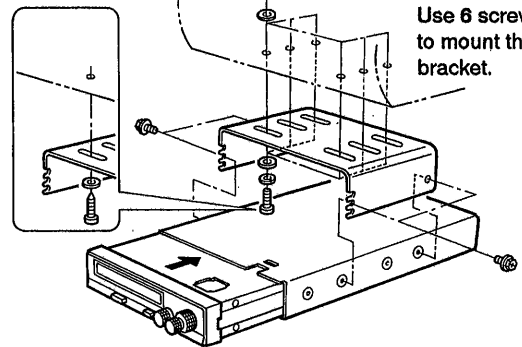

- ① Mount the MB-53 to a convenient location in a vehicle where it:
 - can support the weight of the transceiver.
 - does not interfere with the operation of the vehicle.
 - does not interfere with air bags.

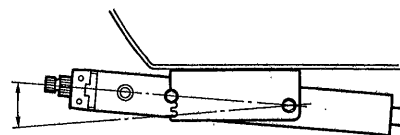

- ② Adjust the angle for good readability of the display.